

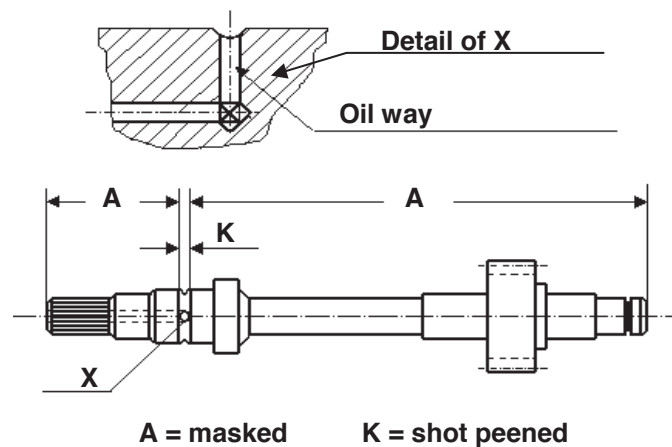

Test report on a masked and shot peened input shaft

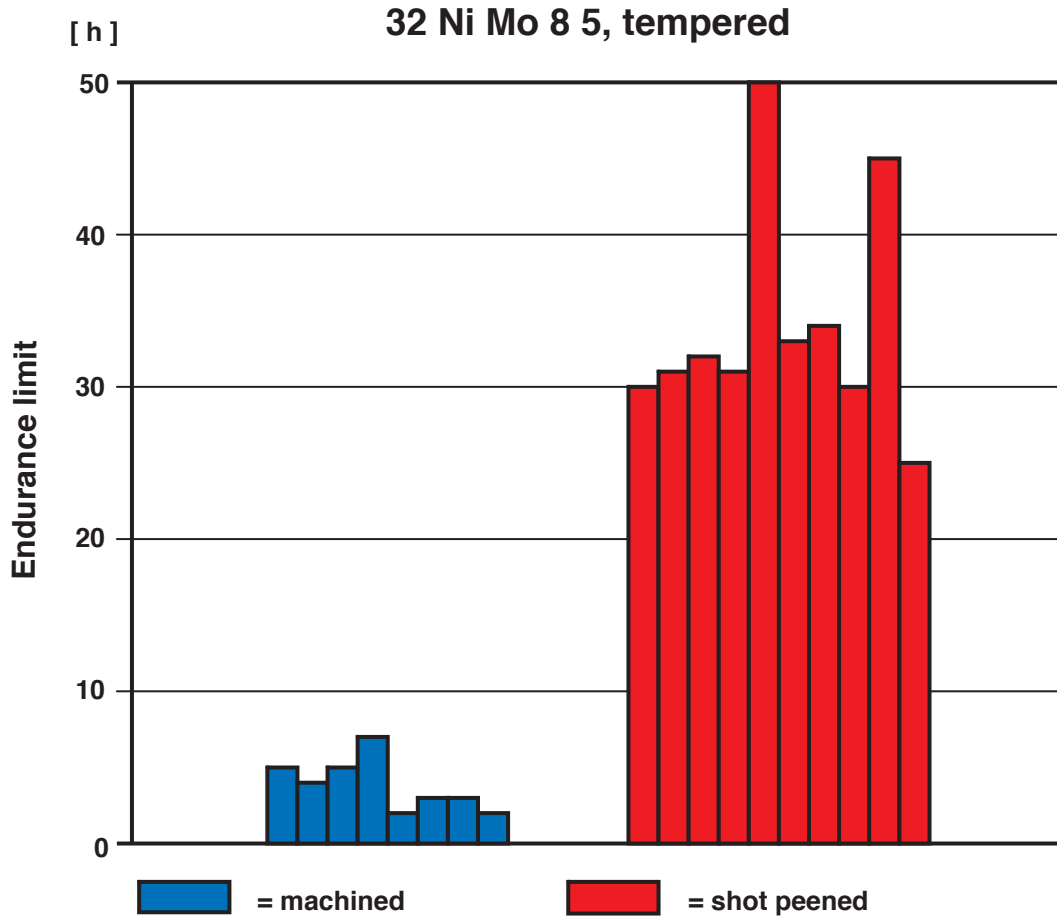

Input shaft

Masking and shot peening

In cases in which the weak areas of a part are well-known it is sufficient to shot-peen only these areas. In cases in which areas of a part should not be peened masking to very close limits is possible. We use elastic adhesive tape or machined plastic covering to achieve this.